

1 FULL ASPECTS - O/H PRIMARY

FOCUS PRIMARY AND OVERHEAD

FOCUS SECONDARY AND TERTIARY

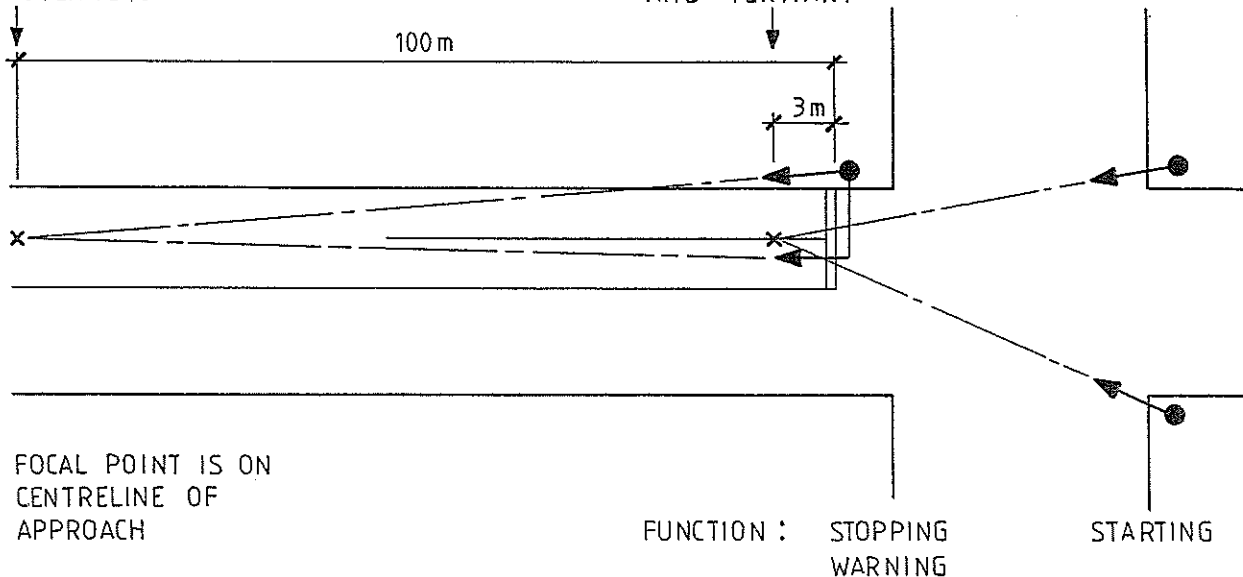

2 FULL ASPECTS - O/HEAD SECONDARY, NO O/HEAD PRIMARY

FOCUS PRIMARY AND OVERHEAD SECONDARY

FOCUS SECONDARY AND TERTIARY

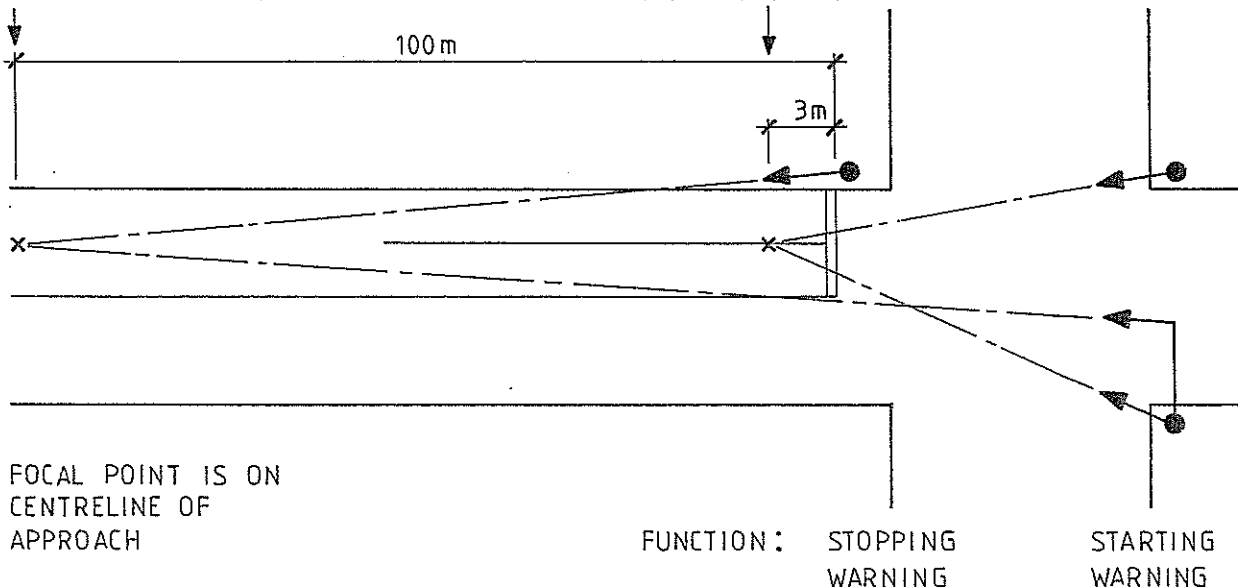

FOCUS : ALL SINGLE O/HEADS FULL GREEN → 100m
 : ALL PRIMARY / DUAL PRIMARY FULL GREEN → 100m

x FOCAL POINT
 - - - - - SITE LINE

DRAWN A.L.M. McCORRY	DATE 30/4/1991	AUCKLAND CITY TRAFFIC ENGINEERING DEPARTMENT	ORIGINAL SCALES NOT TO SCALE
RECOMMENDED <i>[Signature]</i> 26/7/91		"LANTERN ALIGNMENT"	CODE No. FILE No.
APPROVED <i>[Signature]</i>			PLAN No.
SHEET 1 OF 3			

3 FULL ASPECTS — O/HEAD PRIMARY AND O/HEAD SECONDARY

FOCUS PRIMARY AND OVERHEAD PRIMARY

FOCUS SECONDARY, O/HEAD SECONDARY, TERTIARY

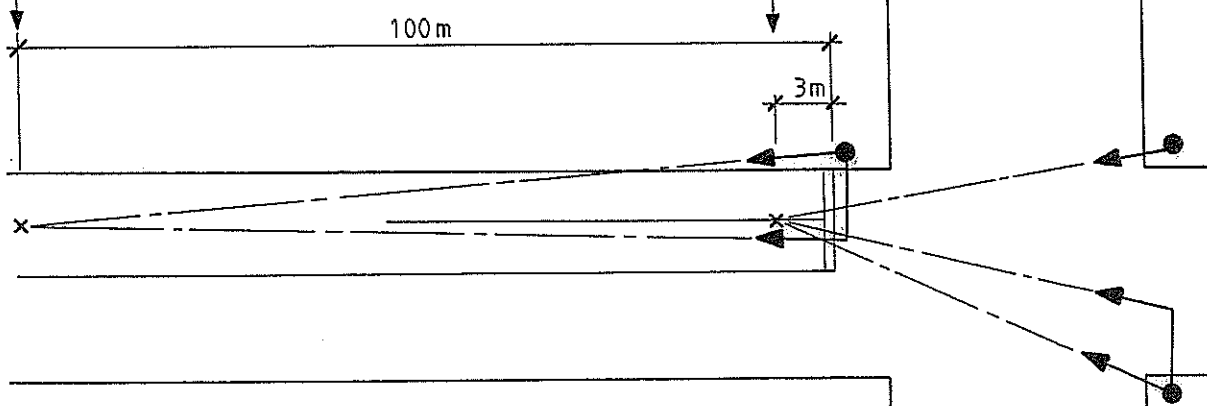

FOCAL POINT IS ON CENTRELINE OF APPROACH

FUNCTION : STOPPING WARNING

STARTING

4 FULL ASPECTS — NO O/HEADS, NO DUAL PRIMARY

FOCUS PRIMARY

FOCUS SECONDARY

FOCUS TERTIARY

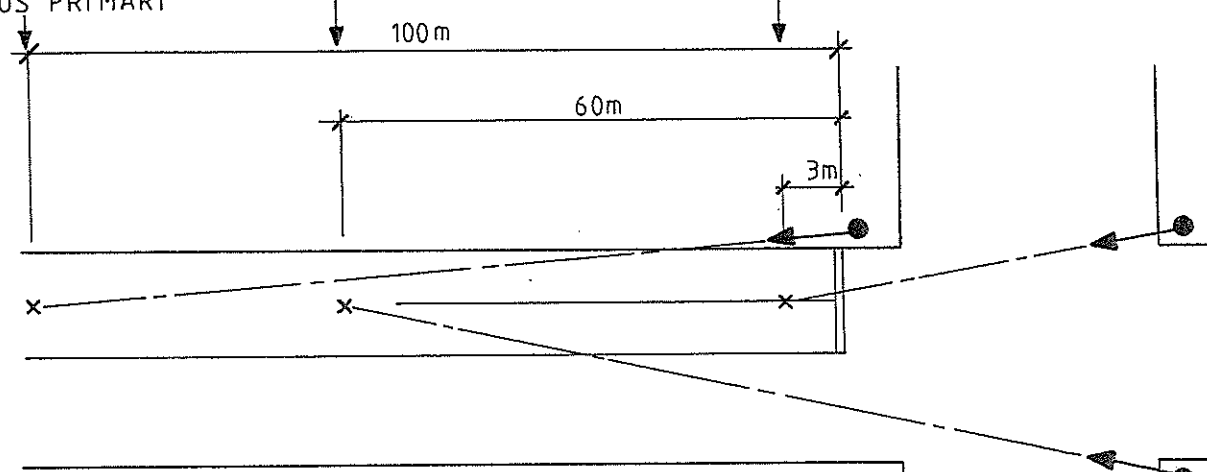

FOCAL POINT IS ON CENTRELINE OF APPROACH

FUNCTION : STOPPING WARNING

STARTING STOPPING

FOCUS : ALL SINGLE O/HEADS FULL GREEN → 100m
 : ALL PRIMARY / DUAL PRIMARY FULL GREEN → 100m

x FOCAL POINT
 - - - - - SITE LINE

DRAWN
 A.L.M. McCRORY 30/4/1991

DATE

AUCKLAND CITY TRAFFIC ENGINEERING DEPARTMENT

ORIGINAL SCALES
 NOT TO SCALE

RECOMMENDED

[Signature] 26/7/91

APPROVED

[Signature]

"LANTERN ALIGNMENT"

CODE No.

FILE No.

PLAN No.

SHEET 2 OF 3

5

FULL ASPECTS — NO O/HEADS, NO DUAL PRIMARY, NO TERTIARY

FOCUS PRIMARY

FOCUS SECONDARY

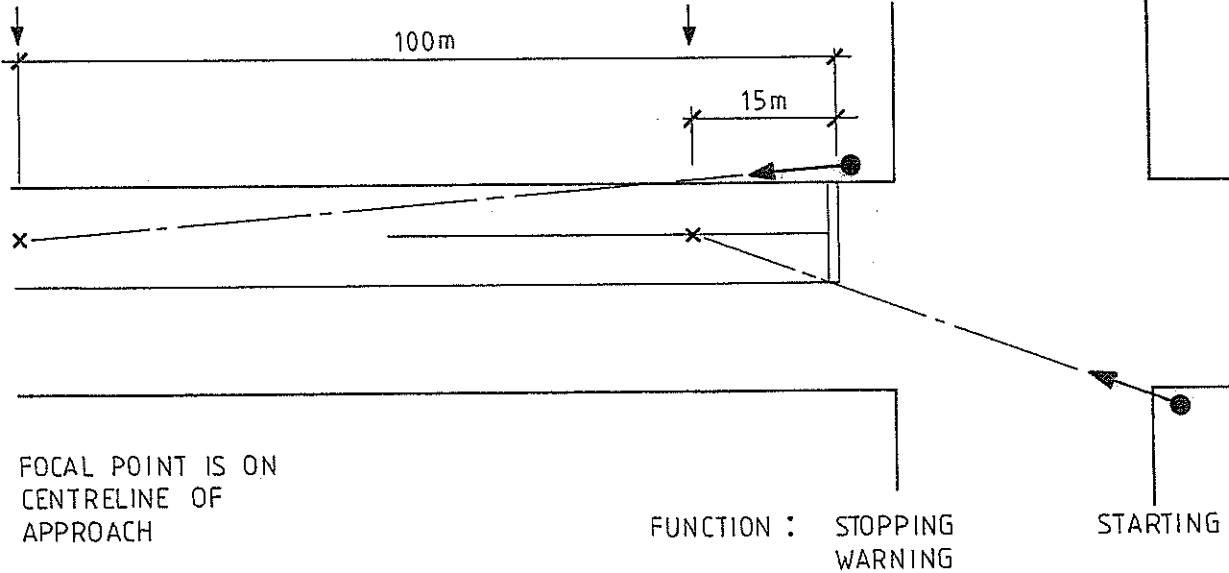

FOCAL POINT IS ON CENTRELINE OF APPROACH

FUNCTION : STOPPING WARNING

STARTING

6

ARROWS — RED, YELLOW, GREEN

FOCUS PRIMARY OVERHEAD PRIMARY

FOCUS SECONDARY, SECONDARY O/HEAD, TERTIARY, TERTIARY O/HEAD

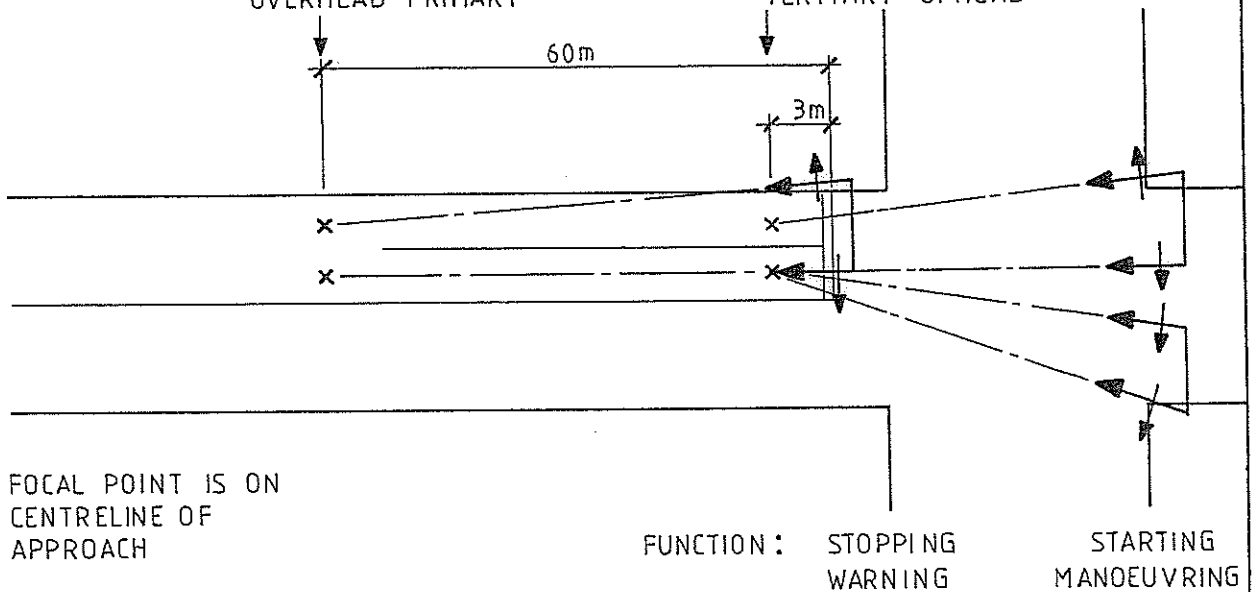

FOCAL POINT IS ON CENTRELINE OF APPROACH

FUNCTION : STOPPING WARNING

STARTING MANOEUVRING

FOCUS : ALL SINGLE O/HEADS FULL GREEN → 100m
 : ALL PRIMARY / DUAL PRIMARY FULL GREEN → 100m

x FOCAL POINT
 --- SITE LINE

DRAWN A.L.M. McCORRY	DATE 30/4/1991	AUCKLAND CITY TRAFFIC ENGINEERING DEPARTMENT		ORIGINAL SCALES NOT TO SCALE	
RECOMMENDED <i>Ey Boyd</i> 26/7/91		"LANTERN ALIGNMENT"		CODE No.	FILE No.
APPROVED <i>McDonald</i>				PLAN No.	
SHEET 3 OF 3					